

# NEURO-IOM (v. 2)

Multimodal System  
for Intraoperative  
Neurophysiologic  
Monitoring

US-EDITION



Neuro-IOM is a cutting edge modular platform solution that combines the years of knowledge and experience obtained in clinical and research environments. Due to flexible configuration options the system can meet the most exacting needs of both surgeon and advanced neuromonitoring specialist.

The high-performance system ensures the full flexibility to the user. The predefined configurations are intended for almost all types of surgery procedures and ensure the simple workflow thanks to intuitive user interface. Any parameter can be changed on-the-fly during the recording and easily interpreted. The time-synchronized video and audio data contribute to obtaining the reliable and accurate results.

We continue mastering the most recent technologies, implementing robust hardware and software tools to stand on the forefront of IONM devices.





Neuro-IOM  
Neurosoft

# COMPREHENSIVE SOLUTION FOR OPERATING ROOM

Neuro-IOM is our recent development for intraoperative neurophysiologic monitoring. The system ensures full-featured performance due to the high-quality and low-noise signal acquisition, configurable display options, and auditory and visual feedback. The modern design with color-coded amplifier outputs and pods allows a specialist to speed up the startup procedure.

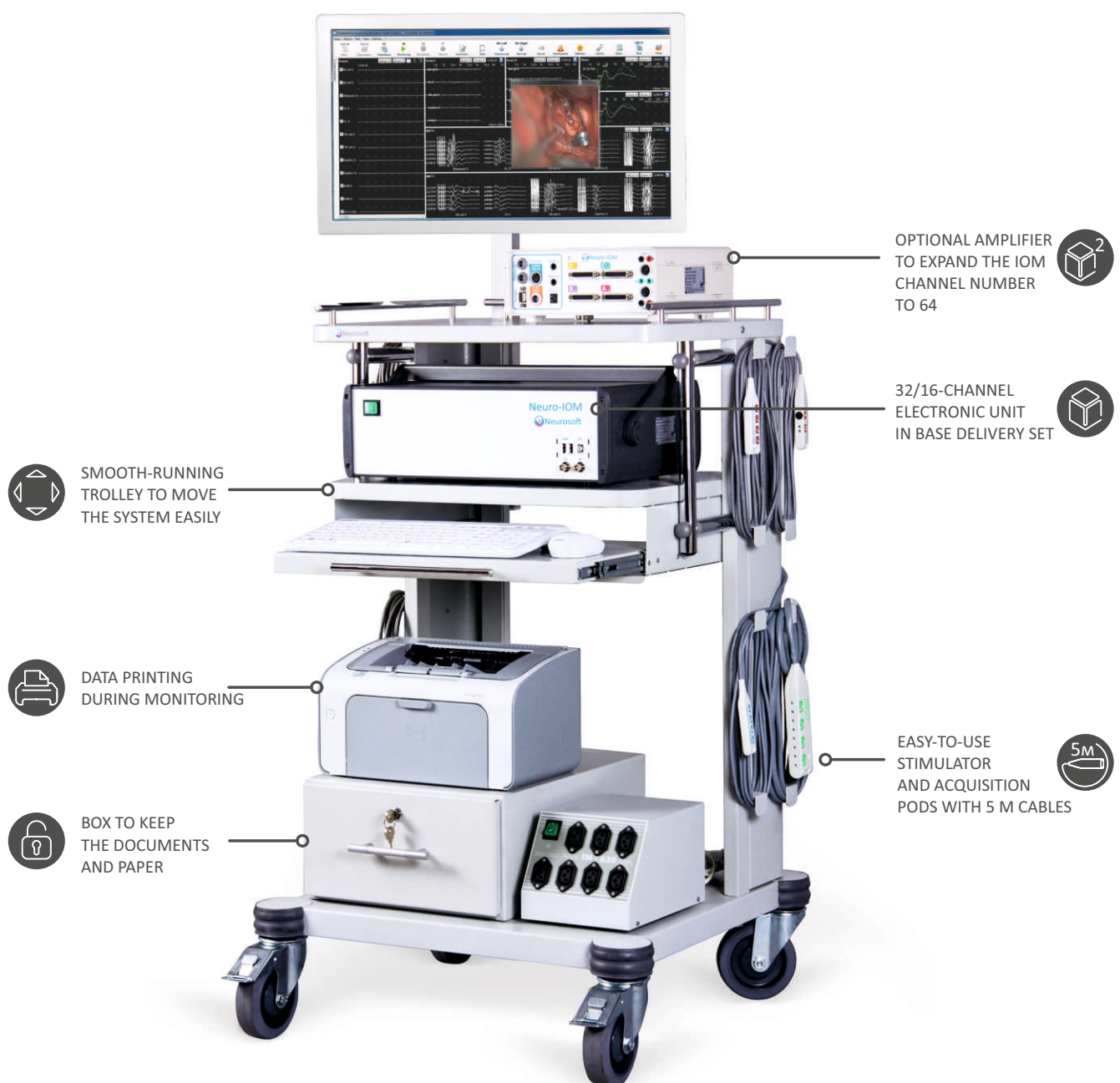

# SYSTEM ARCHITECTURE

Neuro-IOM system consists of electronic unit with built-in amplifiers and stimulators, several pods with 5-meter extension cables, set of special electrodes and dedicated software.

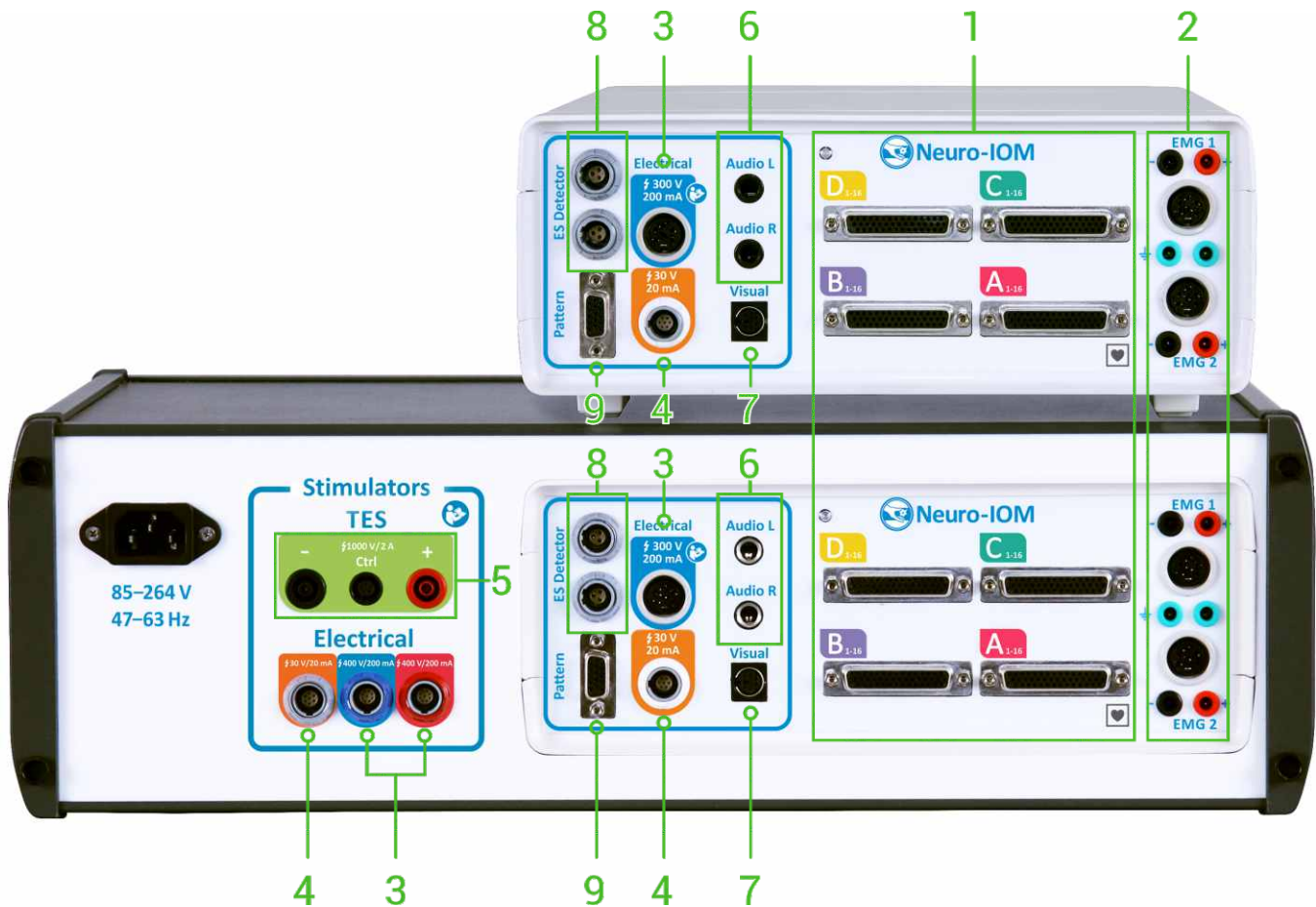

## Main Specifications

- |   |   |   |                              |
|---|---|---|------------------------------|
| 1 | up to 64 universal amplifier channels   | 6 | auditory stimulator channels |
| 2 | up to 4 dedicated channels for routine EMG, NCS and EP  | 7 | visual stimulator channels   |
| 3 | up to 16 electrical stimulator channels   | 8 | up to 4 ES detector channels |
| 4 | up to 3 low current stimulator channels   | 9 | pattern-stimulator channel   |
| 5 | up to 4 transcranial electrical stimulator channels<br>(can be switched to different outputs) |   |                              |

Motor evoked potentials (MEP) are used to control the motor pathways, somatosensory evoked potentials (SEP) are to control the sensory pathways, electroencephalogram (EEG) is to assess anesthesia depth, brain ischemia, epileptiform abnormalities, and direct nerve stimulation is to monitor peripheral nerve integrity. Besides, many other modalities (free-run EMG, AEP, VEP, etc.) can be recorded.

NEURO-TES  
ELECTRONIC SWITCH

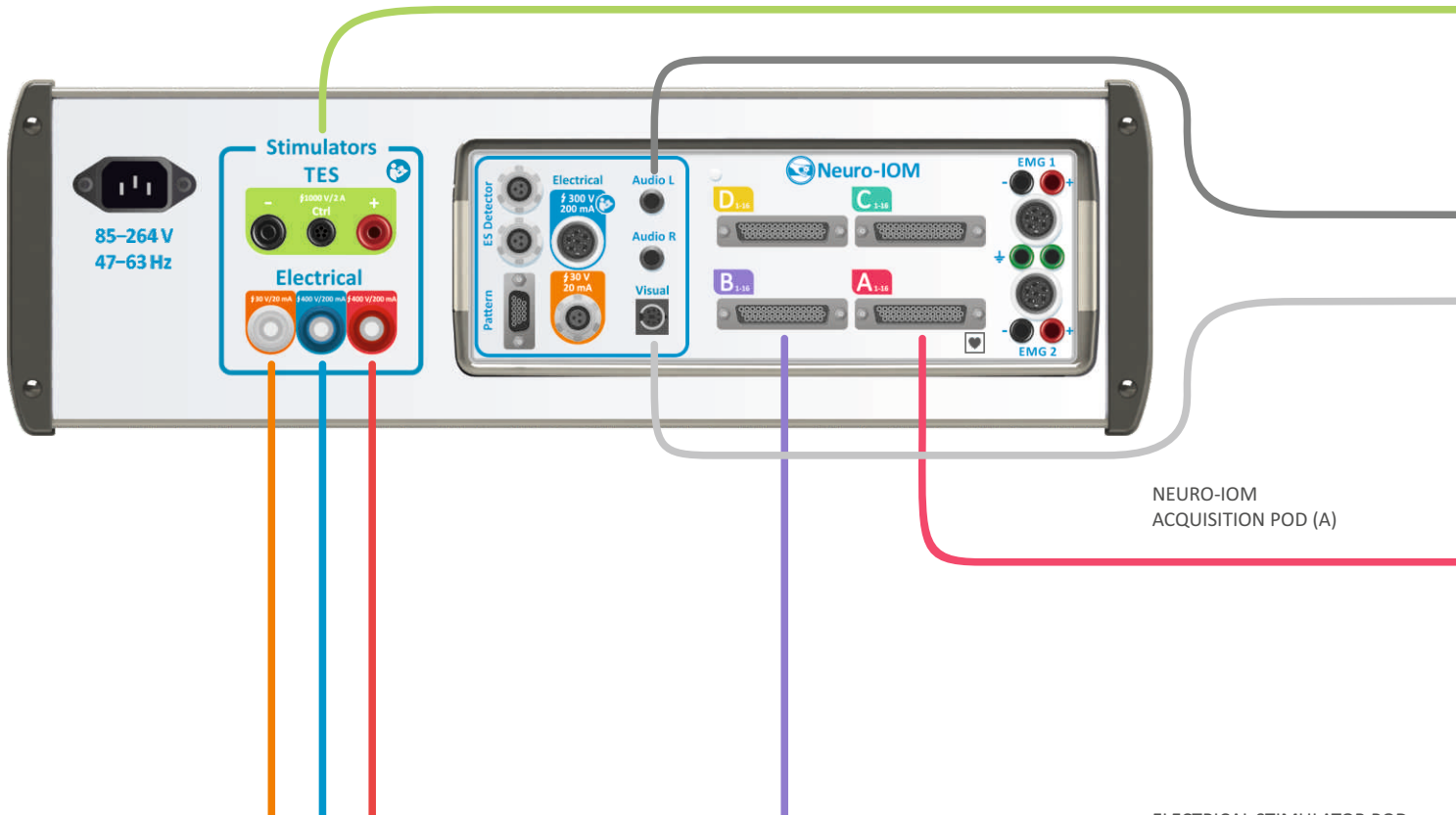

NEURO-IOM  
ACQUISITION POD (A)

ELECTRICAL STIMULATOR POD  
(FOR 1-4 CHANNELS)

LOW CURRENT  
STIMULATOR POD

NEURO-IOM  
ACQUISITION POD (B)

ELECTRICAL STIMULATOR POD  
(FOR 5-8 CHANNELS)

## IOM MODALITIES

The Neuro-IOM system is delivered with the preset templates ensuring the following modalities: free-run EMG, direct nerve stimulation including pedicle screw test, SEP, MEP, EEG, AEP, VEP, ECoG, direct cortical stimulation, train-of-four (TOF) stimulation.

### PRACTICAL APPLICATION OF MODALITIES:

- Motor evoked potentials (MEP) to evaluate the integrity of motor pathways.
- Somatosensory evoked potentials (SEP) to evaluate the integrity of sensory pathways and detect brain and spinal cord ischemia.
- EEG to record and analyze brain activity (functional state of brain).
- Direct stimulation to control the functional integrity of peripheral nerves.

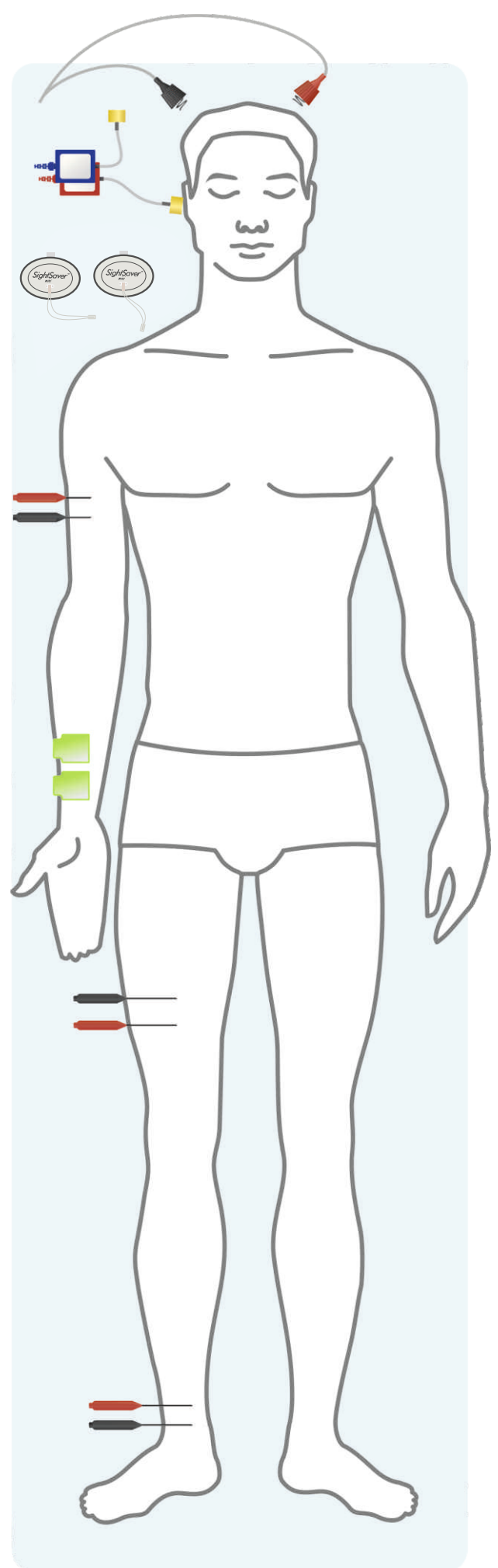
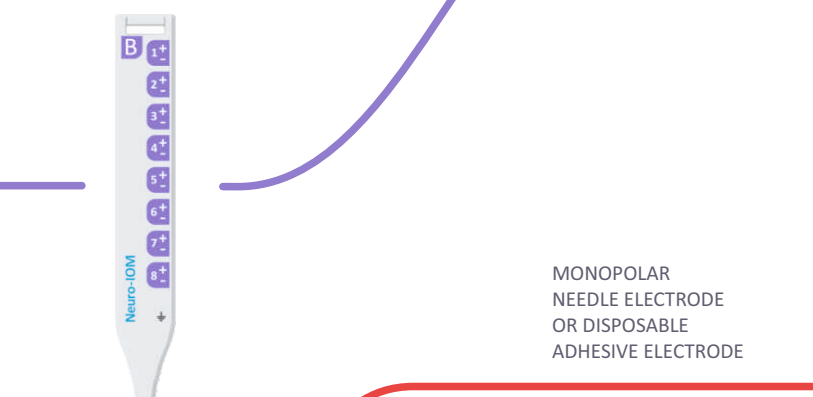
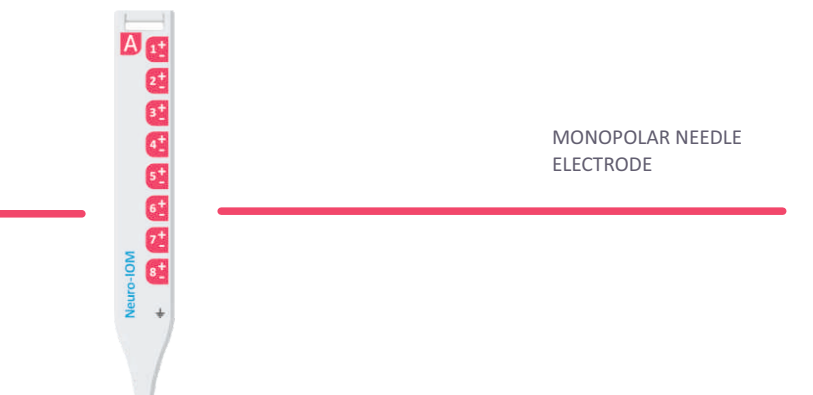
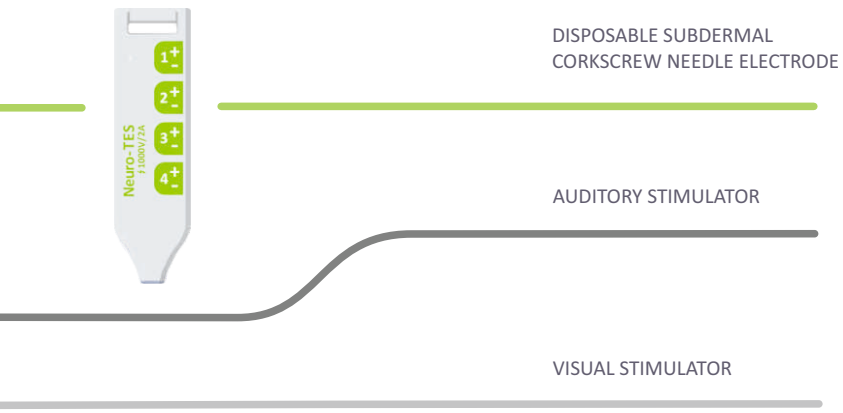

# MULTIMODAL INTRAOPERATIVE NEUROPHYSIOLOGIC MONITORING



## Transcranial Electrical Stimulator

For stimulation of motor cortex in order to elicit motor evoked potentials (MEPs) in peripheral muscles. MEPs allow a specialist to monitor the integrity of motor pathways.

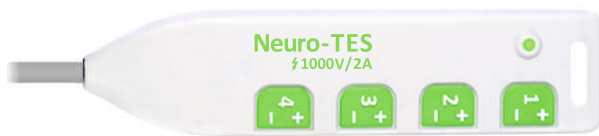

TES Electronic Switch

During the monitoring it is often required to change stimulation site, for example, stimulate left or right side, arm or leg area. For this purpose a special electronic switch is supplied. It has 4 pairs of outputs to attach the stimulating electrodes. A pair of outputs to deliver a stimulus can be chosen in Neuro-IOM.NET software. The corkscrew electrodes are commonly used for the transcranial electrical stimulation.



## Low Current Stimulator

For direct cortex stimulation, direct nerve stimulation and pedicle screw test. During direct nerve stimulation a surgeon can apply the electrical current to the nerves in the operative area of risk using a special probe. At that low current is delivered to the probe. The recording electrodes connected to amplifier are placed on muscles innervated by nerves located in operative area. As soon as a surgeon stimulates a nerve with the probe, the system will record the obtained muscle response. Thus, a specialist will get a direct positive feedback concerning the nerve location. During direct cortical stimulation MEPs are elicited when surgeon stimulates open cortex directly which allows mapping the eloquent brain areas.

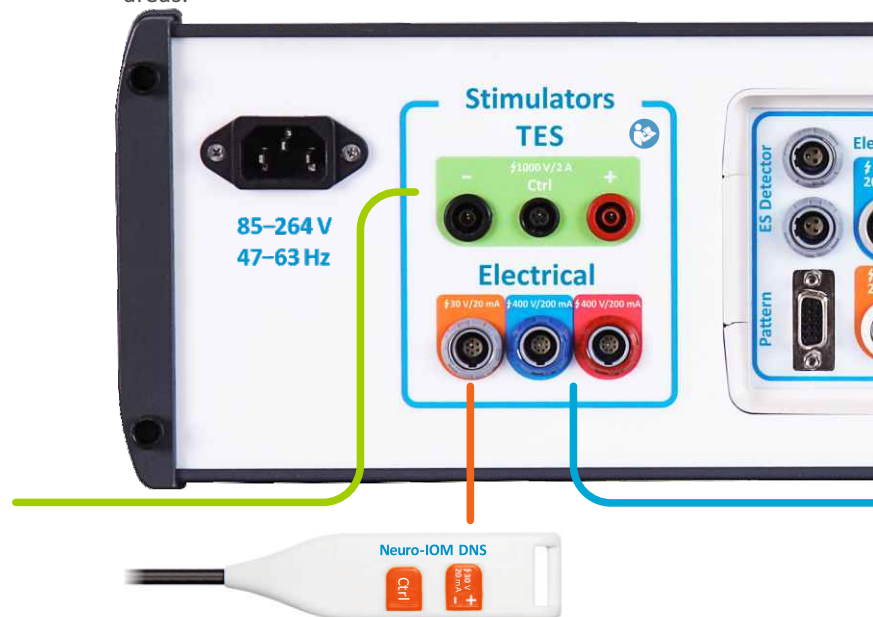

Low Current Stimulator Pod

The pod with 5-meter cable is intended to attach different electrodes for the direct nerve stimulation. The wide range of probes can be used: bipolar, monopolar, concentric, hook, etc.

### IOM APPLICATIONS:

#### 1) Spine surgery:

- cervical/thoracic/lumbosacral decompression surgery;
- pedicle screw positioning;
- intra/extramedullary spinal tumors;
- scoliosis surgery;
- tethered spinal cord syndrome;
- dorsal rhizotomy.

#### 2) Vascular surgery:

- aorta surgery;
- blood vessel replacement;
- endarterectomy;
- heart surgery.





## 8-channel Electrical Stimulator

This device allows stimulating up to 8 peripheral nerves simultaneously or in any sequence to elicit somatosensory evoked potentials (SEP). Using amplifier it is possible to record SEPs obtained from various sites of peripheral nervous system along the efferent pathways. SEPs are sensitive to peripheral nerve events, spinal cord pathway injuries, and also to regional blood flow changes (spinal cord and brain ischemia).



## Amplifier

The system is equipped with a reliable low-noise universal neurophysiological amplifier allowing high-quality acquisition of EMG, EEG and multimodal EPs. The system can be supplied with 16-, 32- or 64-bipolar channel amplifier upon customer's request (16, 32 and 64-channel amplifiers have 32, 64 and 128 inputs correspondingly).

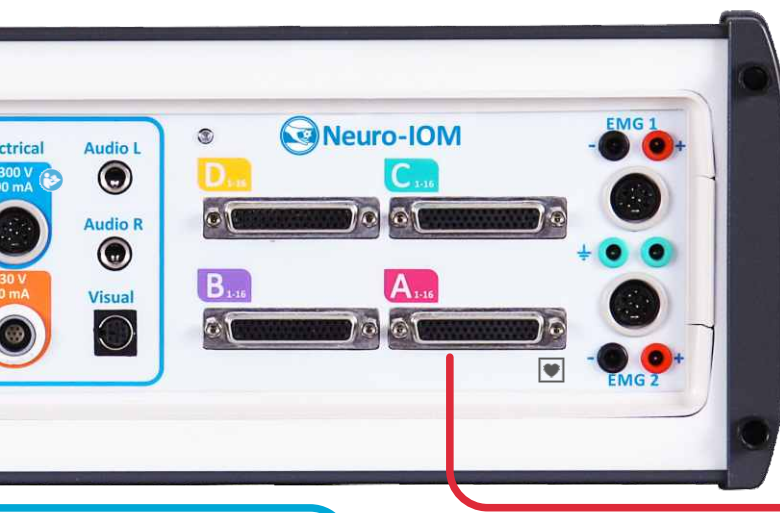

### Electrical Stimulator Pods

The system is equipped with 2 electrical stimulator pods (for channels 1-4 and 5-8). Each pod has 4 pairs of outputs to attach the stimulating electrodes. The outputs can function simultaneously. The electrodes placed at upper extremities are connected to one pod, and at lower extremities – to another one.



### Acquisition Pods

The system is equipped with several pods with 5-meter shielded cables to attach the recording electrodes. The electrodes are usually placed according to the selected test. The signal acquisition at IOM is mostly done with the subdermal needle or corkscrew electrodes.

3) Brain surgery. Intraoperative brain and cranial nerve monitoring. Mapping of functional areas of brain cortex and brainstem:

- brain tumors (and other abnormalities in motor, sensory, auditory, visual cortical areas and their pathways);
- facial nerve monitoring;
- epilepsy surgery;
- recurrent laryngeal nerve monitoring during neck and thyroid surgery;
- movement disorder surgery;
- chiasmo-sellar area (CSAB) monitoring;
- aneurism clipping.

# NEURO-IOM.NET SOFTWARE

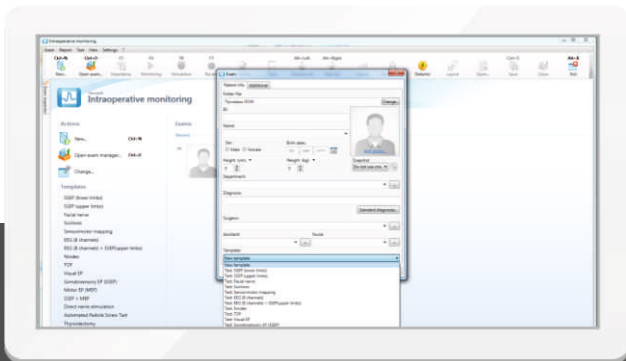

## Monitoring start

To begin the monitoring, just enter patient's data and choose one of test templates. The system provides a set of default templates for various types of surgeries.

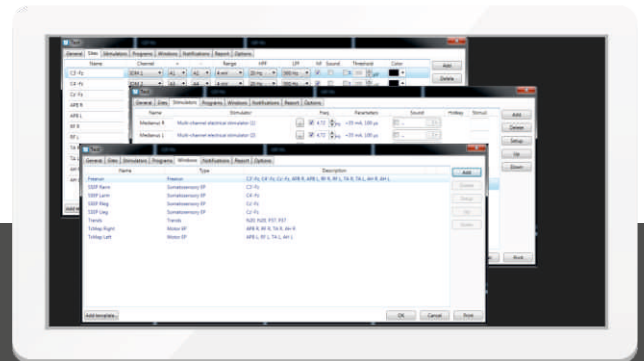

## Test template editor

You can create your own test templates or edit existing ones by selecting stimulation and recording sites and also adjusting the stimulation parameters for current clinical case.

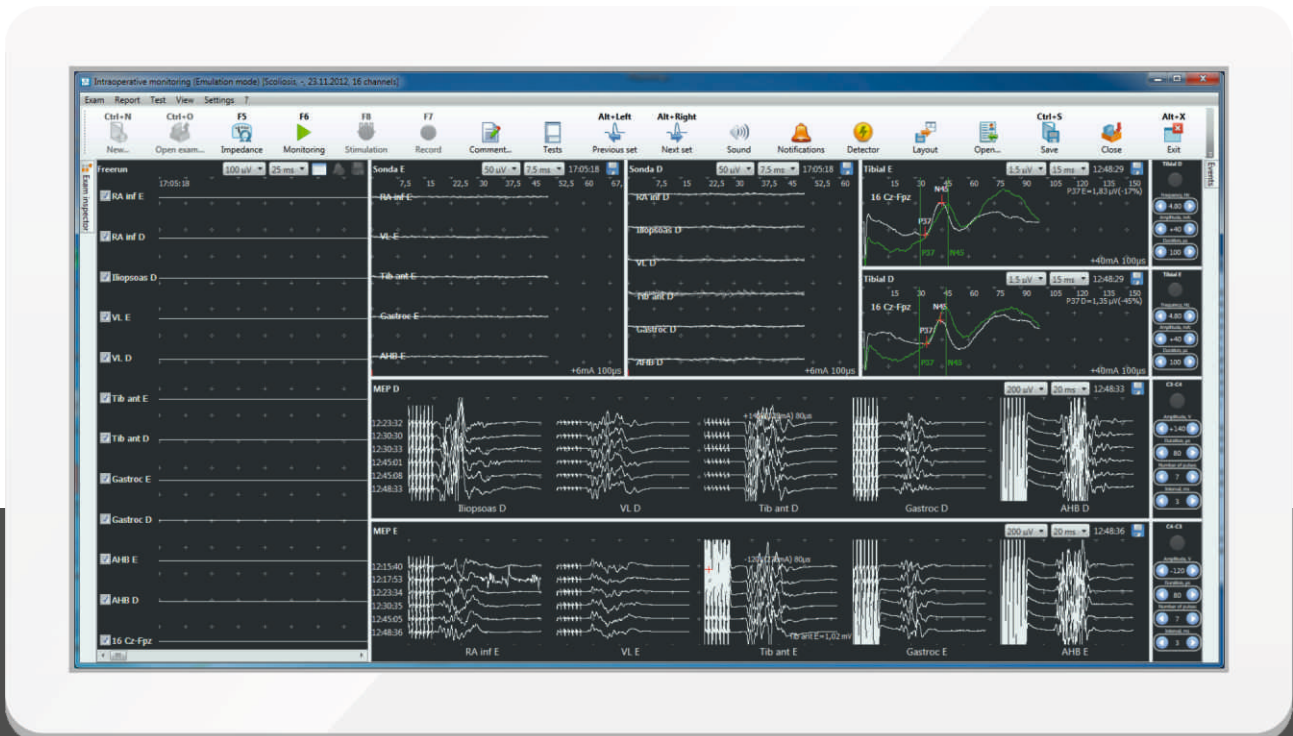

## Test window layouts

The possibility to create various layouts of test windows and quick switching between them allows accommodating a huge amount of information obtained during multimodal monitoring.

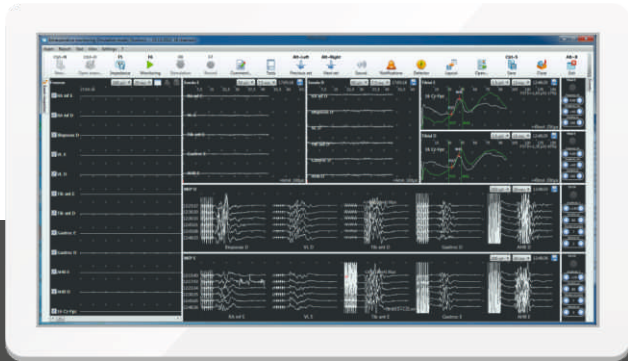

### Data windows

The traces of different modalities can be displayed simultaneously (SEP, MEP, free-run EMG, etc.). It is also possible to view only last obtained traces or traces in "cascade" mode with astronomical time or surgery start time tag. The current traces can be compared with baseline ones.



### "Trends" window

It is possible to view the graphs showing the dynamics during the surgery displayed as trends.

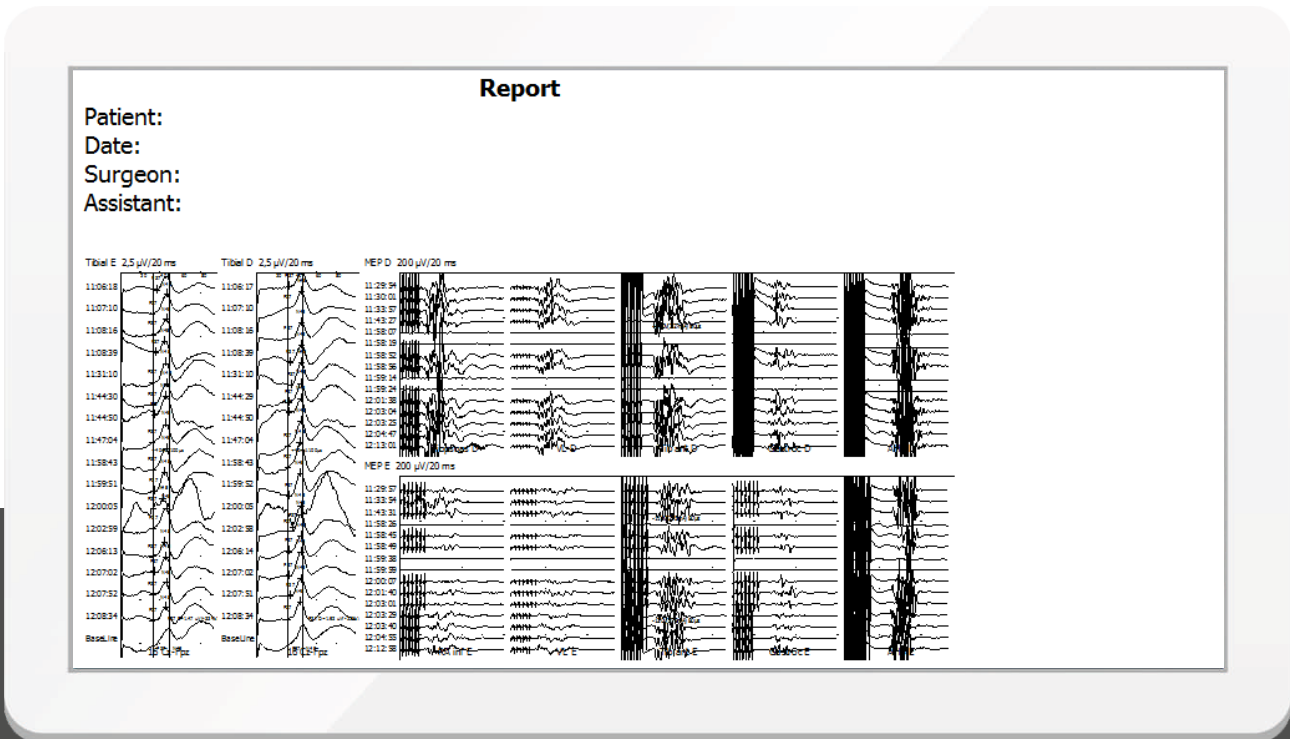

### Monitoring report

The software allows automatically generating the monitoring report in .rtf or Word format. The report includes traces and text comments. It can be edited using the built-in editor or Microsoft Word and printed on office PC printer.

# NEURO-IOM VERSIONS



USB CONNECTION



## Neuro-IOM

32/B

IOM channel	32
Dedicated channel for routine EMG, NCS and EP	2
Electrical stimulator channel	12
Low current stimulator channel	2
Transcranial electrical stimulator channel	4
Auditory stimulator channel	2
Visual stimulator channel	2
ES detector channel	2
Pattern-stimulator channel	1



### 32/S

### 16/S

32	16
2	2
4	4
1	1
–	–
2	2
2	2
2	2
1	1

The system can be supplied in one of four configurations depending on the needs of neurophysiologists and surgeons.

The configurations differ in the number of channels and application at different types of surgeries.

The system can be supplied with desktop or laptop computers.

# ACCESSORIES



Neuro-IOM acquisition pod (8 channels, 5 m cable)

Application: connection of recording electrodes to the amplifier

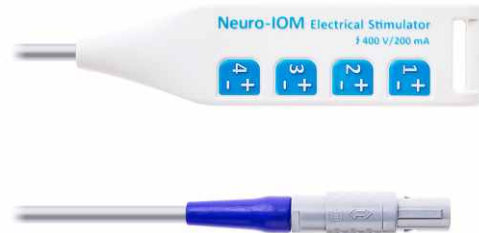

Electrical stimulator pod (4 channels, 5 m cable)

Application: connection of stimulating electrodes to the electrical stimulator

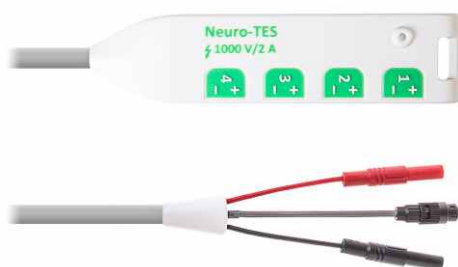

Neuro-TES electronic switch

Application: switching of high-amplitude stimuli for transcranial electrical stimulation



Low current stimulator pod (5 m cable)

Application: connection of stimulating electrodes to the low current stimulator for direct nerve or cortical stimulation



Neuro-TES transcranial electrical stimulator

Application: generation of high-amplitude stimuli for transcranial electrical stimulation



ES detector

Application: pausing the recording and preventing the system from storing electro-surgical noise, if electrosurgery devices are used



SightSaver™ evoked potential stimulator

Application: generation of light flashes to record VEPs during surgery

CAUTION: Federal Law restricts this device to sale by or on the order of a practitioner licensed by the law of the State in which he/she practices to use or order the use of the device.



[www.neurosoft.com](http://www.neurosoft.com), [info@neurosoft.com](mailto:info@neurosoft.com)  
Phones: +7 4932 24-04-34, +7 4932 95-99-99  
Fax: +7 4932 24-04-35  
5, Voronin str., Ivanovo, 153032, Russia

July 2021